

Piper Aircraft Corporation

Lock Haven, Pennsylvania, U.S.A.

F.A.A. Approved

**SUBJECT:** Replacement or Modification of Muffler Shrouds

**MODELS AFFECTED:** PA-24 and PA-24 "250" Comanches - Serial Numbers 24-2588 to 24-2875 incl., 24-2877 to 24-2928 incl., 24-2930 to 24-2948 incl., 24-2950 to 24-2966 incl., 24-2968 to 24-2989 incl., 24-2991 to 24-3032 incl., 24-3034 to 24-3094 incl., 24-3096 to 24-3113 incl., 24-3115 to 24-3129 incl., 24-3131 to 24-3149 incl., 24-3151 to 24-3154 incl., 24-3156 to 24-3172 incl., 24-3174 to 24-3190 incl., 24-3192, 24-3195, 24-3197, 24-3199 to 24-3202 incl., 24-3205 to 24-3221 incl., 24-3223 to 24-3232 incl., 24-3235 to 24-3240 incl., 24-3242, 24-3243, 24-3245, 24-3246, 24-3247, 24-3249 to 24-3253 incl., 24-3255, 24-3256, 24-3259 to 24-3264 incl., 24-3266, 24-3267, 24-3269, 24-3271, 24-3272, 24-3275, 24-3281, 24-3284 and all of the referenced aircraft prior to Serial No. 24-2588 in which mufflers, part number 22594-00 and part number 22594-02 PA-24, and part number 22593-00 and part number 23159-00 PA-24 "250", have been installed as service replacements.

**DATE OF COMPLIANCE:** Prior to but not later than next 50 hours of operation

Service reports have been received advising of cracks located in the muffler housing near the tailpipe reinforcement strap. The muffler heater shroud has therefore been redesigned to remove the affected area from the heater system. This has been accomplished by increasing the shroud opening around the tailpipe, making the area more accessible for inspection.

Comanche mufflers have been manufactured incorporating two different styles of tailpipe reinforcement brackets. However, this Service Bulletin requires modification of one style only; those with the channel-shaped reinforcement. See Sketch "A" for further identification. Both styles of muffler have been sold as service replacements. It will therefore be necessary to inspect aircraft, Serial Nos. 24-1 to 24-2587 inclusive if the original muffler has been replaced, to determine if compliance with this Bulletin is required.

Aircraft, Serial Nos. 24-2588 through 24-3284 inclusive, were manufactured with the channel-shaped reinforcement and will require modification, except those already modified as indicated by serial numbers omitted under models affected.

RECOMMENDED AIRCRAFT INSPECTION PROCEDURE  
Aircraft Serial Nos. 24-1 to 24-2298 inclusive  
(Mufflers with channel reinforcement only)

1. Remove the tailpipe.
2. Remove the right hand exhaust stack and inspect for cracks, etc., paying particular attention to the junction of rear cylinder exhaust tube with the stack assembly.
3. Remove the muffler. This can be accomplished by taking the muffler out the right side, without removing the left exhaust stack.
4. Remove muffler heater shroud.
5. Carefully inspect the muffler for visible cracks, particularly the area near the tailpipe opening. Inspect the internal baffle and perforated tube. Submerge the muffler in water and pressure test at 10 p.s.i.

If cracks or other defects are observed, leaks detected during pressure test, or wrinkles found in the perforated tube, the muffler must be replaced.

6. Remove the cold air inlet take-off assembly located on the aluminum heater shroud.
7. Cut out the enclosed template and place on the aluminum shroud over the present tailpipe opening.
8. Cut the new opening in the aluminum shroud, taking care not to cut past the splice. (See Note Sketch "B.")
9. Install the muffler housing reinforcement tube, part number 23482-00, on the inside of the aluminum heater shroud. (See Sketch "B.")
10. Relocate the cold air inlet take-off assembly as shown on the take-off relocation table and install cover plate, part number 23498-00, over old hole. Trim cover plate as required. (See Sketch "B.")
11. Reinstall the aluminum shroud on the muffler. The tailpipe should be centered in the shroud tailpipe opening.
12. Reinstall the muffler, exhaust stack, tailpipe, etc., on the aircraft.
13. The referenced material required for the heater shroud modification is contained in Kit, part number 754 484.

**Aircraft Serial Nos. 24-2299 to 24-3284 inclusive  
(Mufflers with channel reinforcement only)**

Steps numbers 1 through 5 -- Same as for Serial Numbers 24-1 to 24-2298 inclusive.

6. Install new cabin heater shroud, part number 23507-00 on PA-24, and part number 23489-00 on PA-24 "250." The tailpipe should be centered in shroud tailpipe opening.

7. Install the muffler, exhaust stack, tailpipe, etc. on the aircraft.

We have been aware that in some instances, inspection of the exhaust systems has not been as thorough as it should have been and are, therefore, attaching to this Bulletin a copy of our Service Letter No. 324B covering that subject.

**NOTE FOR DISTRIBUTORS**

Distributors should order muffler shrouds, part number 23507-00 PA-24, and part number 23489-00 PA-24 "250," in sufficient quantities to comply with this Bulletin.

Credit will be issued for these shrouds and three (3) hours warranty labor will be approved upon receipt of a Warranty and Credit Claim.

Distributors should order kit number 754 484 in sufficient quantities for muffler shroud modification.

PA-24 "250" Comanches, Serial Nos. 24-103 to 24-2298 inclusive, using muffler shroud, part number 21577-00, will require a longer flex tube. An order for this tube, part number 22502-25, should accompany the order for the kit.

Credit will be issued for kit number 754 484 and five (5) hours warranty labor upon receipt of a Warranty and Credit Claim.

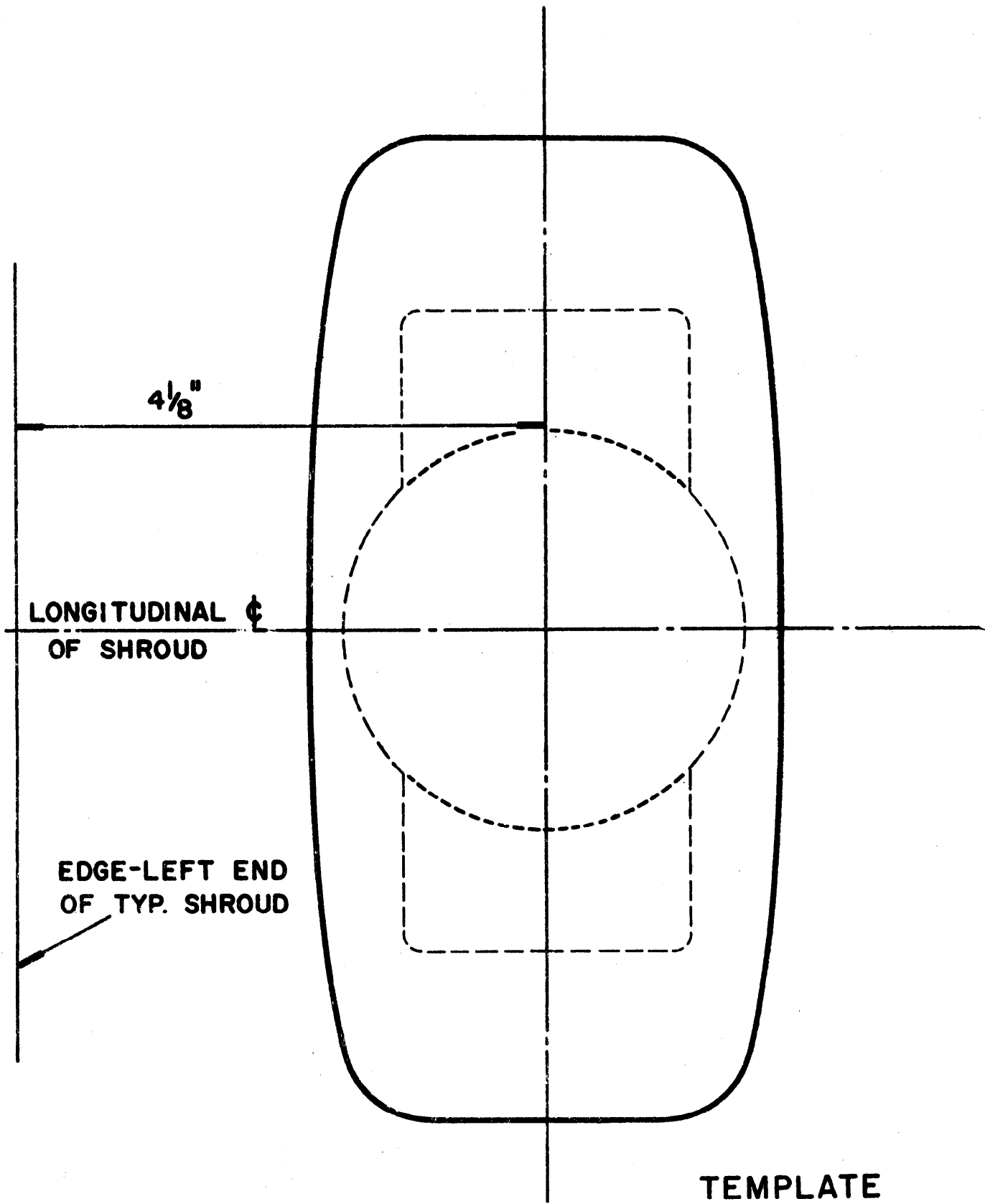

4 1/8"

LONGITUDINAL CENTERLINE  
OF SHROUD

EDGE-LEFT END  
OF TYP. SHROUD

TEMPLATE  
NEW SHROUD HOLE  
ACTUAL SIZE

RELOCAT. 2" DIA. TAKE-OFF HOLE  
SEE TAKE-OFF RELOCATION TABLE

ON SHROUDS WITH SPLICE AT 45°  
DO NOT CUTOUT OR RIVET  
ABOVE SPLICE

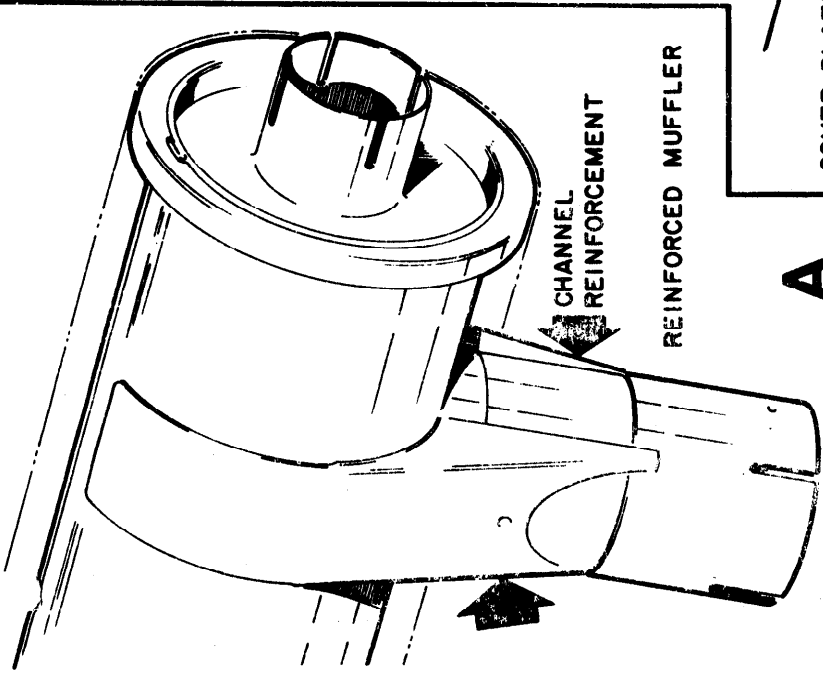

**A**

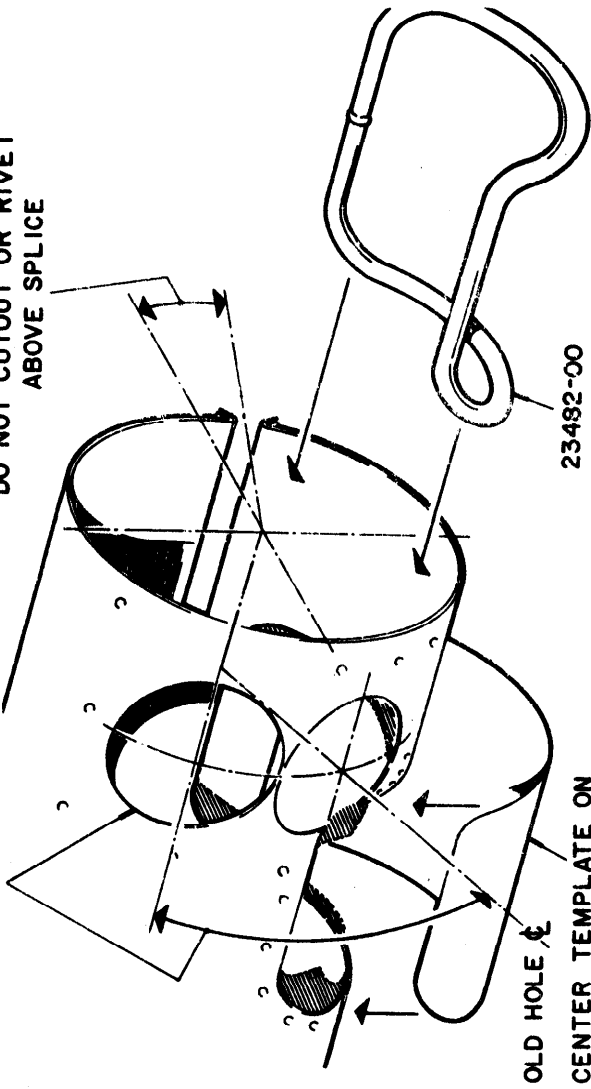

OLD HOLE  
CENTER TEMPLATE ON  
OLD EXHAUST STACK HOLE  
USING ATTACHED TEMPLATE

23482-00

**B**

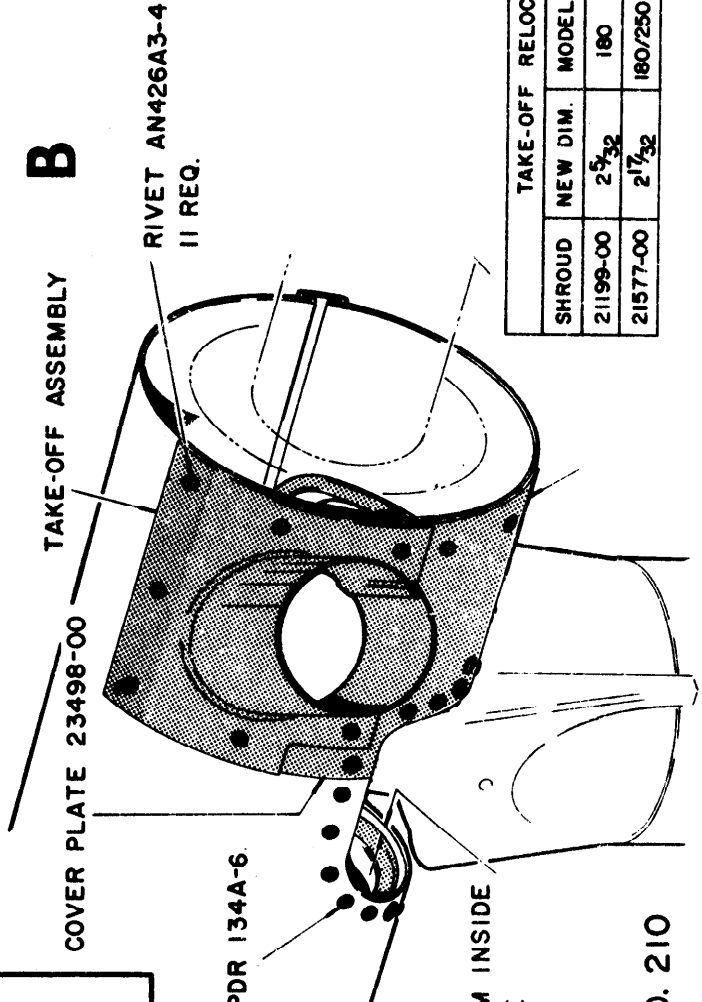

COVER PLATE 23498-00  
TAKE-OFF ASSEMBLY

RIVET AN426A3-4  
11 REQ.

RIVET PDR 134A-6  
20 REQ.

CUTOUT APPROX. 1/8" FROM INSIDE  
OF REINF. TUBE

TAKE-OFF RELOCATION TABLE			
SHROUD	NEW DIM.	MODEL	SERIAL NO.
21199-00	2 5/32	180	24-1 TO 24-102 INCL.
21577-00	2 17/32	180/250	24-103 TO 24-2298 INCL.